



RJG Lynx Surface Mount Analog Input Module

IA1-S-VI-24

Installation and Applications

RJG, Inc.

© 2008

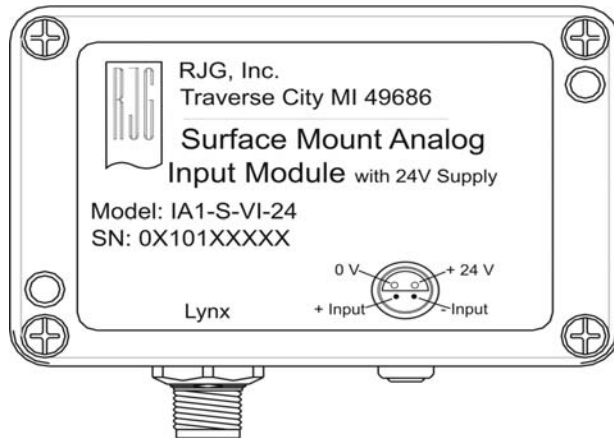



This symbol is used as an operational safety symbol for all work that involves a risk of life and limb for personnel. This symbol also identifies information about practices or circumstances that can lead to personal injury or death, property damage or economic loss. Where this symbol appears throughout this manual, please exercise particular care and caution while carrying out tasks.



This symbol is used as an operational safety symbol for all work that involves risk of electrocution. For instance, it can represent areas of high voltage where power should be disconnected in advance to any servicing.



RJG Lynx Surface Mount Analog Input Module IA1-S-VI-24

General Description

The Lynx Surface Mount Analog Input Module is an isolated analog input module that can be configured to input either 0-10V or 4-20mA signals. In addition the Lynx Surface Mount Analog Input Module can supply a 24V power source that can be used to power certain sensors. This module can be mounted wherever needed including inside or outside the molding machine and on or within auxiliary equipment.

Applications

This module can be used to interface with any sensor that outputs 0-10V or 4-20mA signals. Examples of this may include:

- Temperature
- Dew Point
- Plastic or Hydraulic Pressure

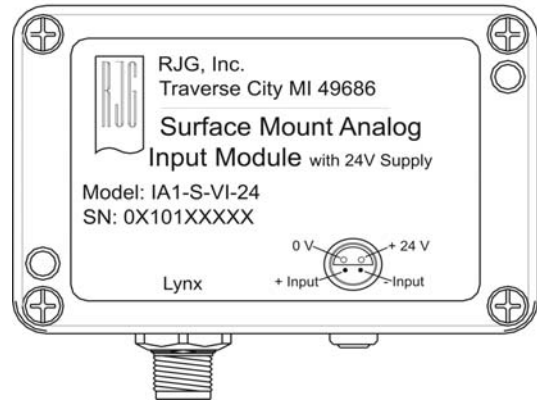

Specifications

| | |
|------------------------------------|-------------------------|
| Input Range | |
| *0-10V Mode | 0V to 10V |
| 4-20mA Mode | 4mA to 20mA |
| Output Range | |
| Voltage Range | 23-26V |
| Maximum Drawable Current | 100 mA |
| Case Temperature Range: | 0 - 60 °C (32 - 140 °F) |
| Accuracy: | +/- .1% FS |
| Maximum Sample Rate: | 500 samples/second |
| Resolution | |
| *0-10V Mode | 2.44 mV per step |
| 4-20mA Mode | 3.9 µA per step |
| *0-10V mode is standard as shipped | |

Table One: Lynx Surface Mount Analog Input Module Specifications



4 - 20mA Set-up

The Lynx Surface Mount Analog Input Module is shipped configured for 0 - 10V operation. To configure the module for 4 - 20mA operation, follow these steps:

Step One: Removal all cables .

Removal all cables from the module and if already mounted remove from installation.

Step Two: Locate Jumper Locations .

Locate the jumper locations JP1 and JP2 as shown in Figure One.

Step Three: Install 4 - 20mA Jumpers .

Install jumpers into jumper locations JP1 and JP2 as seen in Figure Two. The jumpers needed are taped to the lid.

Do not remove or install any other jumpers.

24V Fuse Replacement

The 24V output is fused and a spare is provided on the board (see Figure 2). Remove the fuse (position C) and discard. Replace with the spare (position D)

C → 24V Output Fuse

D → 24V Output Fuse Spare

Fuse Part #: Wickman 3950160044

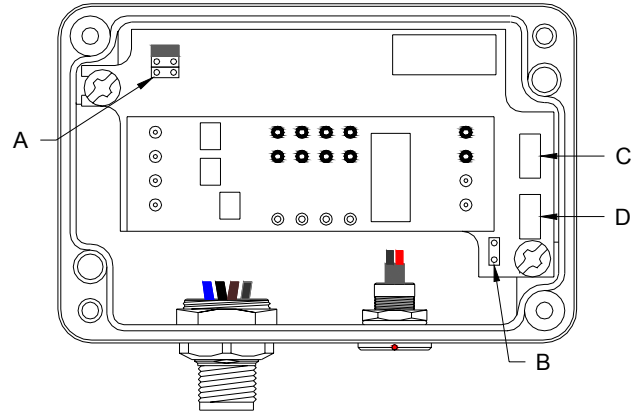
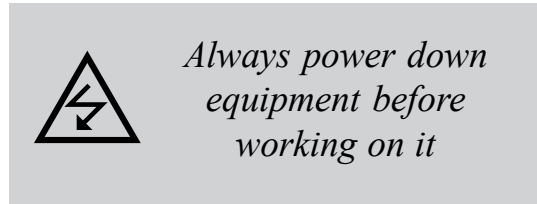

Figure One: Voltage Mode Jumper Setup
A. Jumper location JP1. No Jumper installed.
B. Jumper location JP2. No Jumper installed.
C. 24V Output Fuse
D. 24V Output Fuse Spare

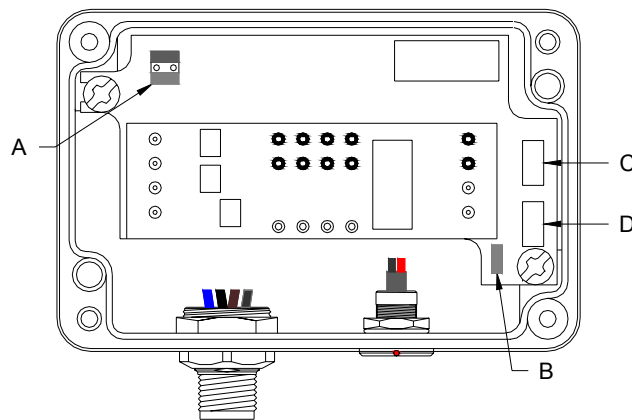

Figure Two: Current Mode Jumper Setup
A. Jumper location JP1. Jumper installed.
B. Jumper location JP2. Jumper installed.
C. 24V Output Fuse
D. 24V Output Fuse Spare



Installation

Step One: Mill Mounting Holes for RJG Lynx Surface Mount Analog Input Module.

Figure One shows mounting hole locations and overall dimensions. Use the following guidelines when determining the mounting location:

- Do not mount in locations subject to high shock or vibration (such as ejector plates or actuating mold components).
- The module must be mounted to surfaces between 0 - 60 °C (32 - 140 °F)

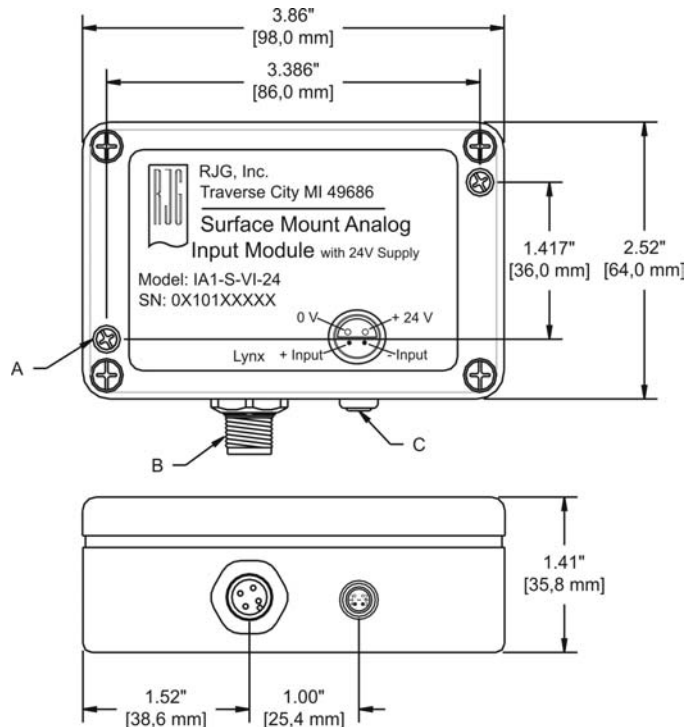



Figure Three

- A. Mounting Hole Dimensions
- B. Lynx communications connector
- C. Analog Input/Voltage Output Connector



Always power down equipment before working on it



Make sure the Analog Input Module and any connecting cables are out of the way of any sources of static such as feeder tubes and material hoppers



Step Two: Mount the RJG Lynx Surface Mount Analog Input Module.

Bolt the RJG Lynx Surface Mount Analog Input Module to the mounting surface.

Step Three: Wire sensor to the Analog Input/Voltage Output Cable.

Wire sensor to the Analog Input/Voltage Output Cable (Refer to Table Two). Consult sensor documentation before wiring. Plug Analog Input Voltage/Output Connector into module. See Figure Four.

Step Four: Connect RJG Lynx Surface Mount Analog Input Module to the eDART™

Connect the Lynx communication cable between the Surface Mount Analog Input Module and the eDART™ communications port.

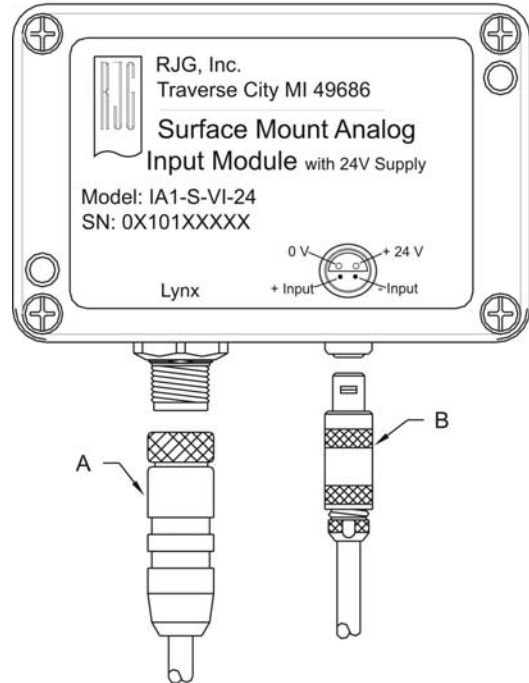

Figure Four
 A. Lynx Communications Connector
 B. Analog Input Voltage/Output Connector

| Signal | Details | Wire Color |
|---------|---|------------|
| + Input | 0 -10V or 4 - 20mA Input (internal jumper selectable) | Blue |
| - Input | Analog Common | White |
| + 24 V | 24V Sensor Power | Black |
| + 0 V | Sensor Power Common | Brown |

Table Two: Analog Input Voltage/Output Connector Wiring Guide



Step Five: Configure the eDART™ Software

The eDART™ Sensor Locations screen will show the Analog Input Module as shown in Figure Five: If the Analog Input Module has not yet been configured, the channel will be named “0 - 10V Input” with no location entered.

Note: even with the Module setup for 4-20mA, the sensor type will read “0 - 10V Input”

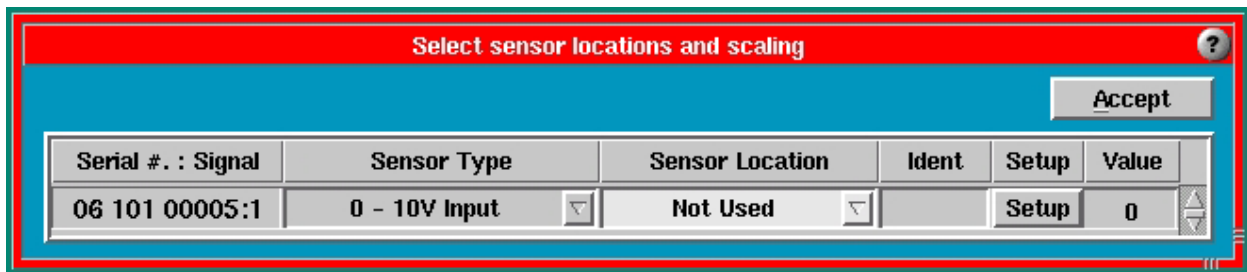

Figure Five: Sensor Locations Screen

Select the Setup button to bring up the setup screen (refer to Figure Six). This will allow access to pull-down menus allowing the setup of many different types of sensors.

Note: you will not be able to specifically scale something for 4 - 20mA. Instead enter the range for 4 - 20mA in for a 0 - 10V span. For example if you sensor puts out 4 - 20mA for 0 - 20,000 psi. Enter 0 psi for 0V and 20,000psi for 10V.

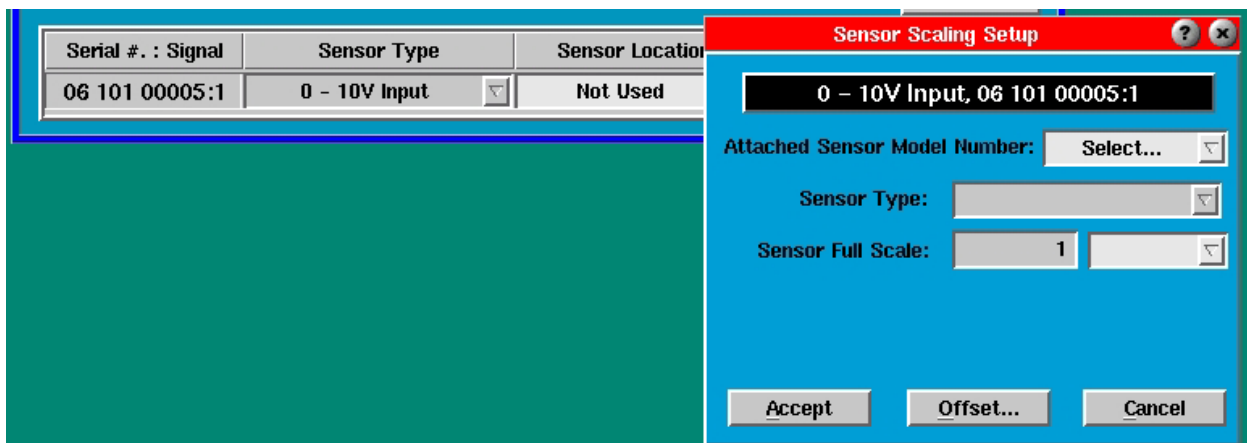

Figure Six: Setup Screen